



Rumba



Rumba®

Compact, transportable, and adjustable...

Super compact base - ideal for lifts and narrow doors

The Quickie Rumba's base is just 59cm (23") wide (with a 42cm (16.5") seat frame width) allowing easy access into lifts and narrow doorways.

Even with the frame size adjusted to its maximum size of 48cm (19") the seat frame is still only 65cm (25.6") wide.



Adjustable and Detachable

Easy to transport

An easily detachable back and lift out batteries, combined with a folding frame and the fact that the heaviest component of the chair weighs just 37.4kg (82.4lbs) makes the Rumba easy to transport, or to store in car boots or other confined spaces.



Easy to store or transport

Easy to adjust

- From 42 to 54cm (16.5 to 21.3") width adjustment
- Frame has 6cm (2.4") armrest width adjustment
- Tool-free backrest height adjustment to 43, 46 and 49cm (17, 18 and 19.3")
- Backrest angle adjustment of up to 30° (complete with adjustable upholstery option)
- Detachable armrest with height adjustment
- 3° of seat angle adjustment



Adjustable width



Height and angle adjustable backrest

Available kits

- Attendant control
- Lever drive attendant control
- Dual control
- Tension adjustable upholstery (grey)
- Anatomic padded seat
- Anatomic padded back
- Angle/depth adjustable footplates
- Standard headrest
- Anatomic headrest
- Swing-over tray
- Amputee support
- Crutch holder



Kerb climber (standard)

Rumba®

Compact, transportable, and adjustable...

Technical specifications

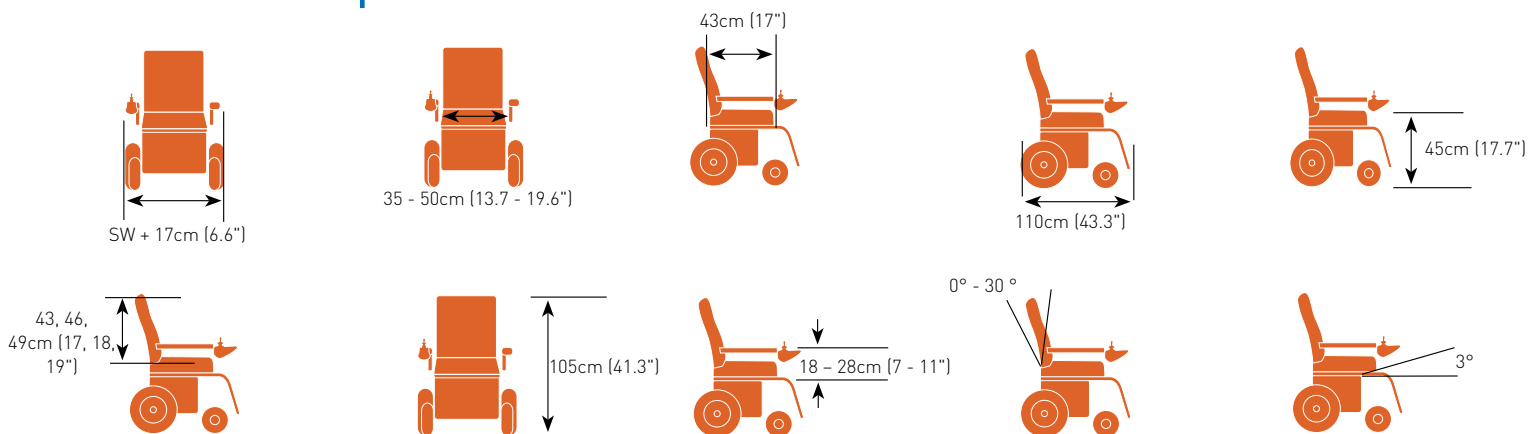

Max. speed	6kph / 3.7mph	Max. safe slope:	10°
Batteries:	40Ah / [50Ah]	Reversing width:	100cm (39.4")
Colours:	Blue, Red, Black and Silver	Max. height of kerb:	100cm (39.4")
Max. user weight:	125kg (19.7 stone)	Max range:	30km (18.6 miles)
Total weight (with batteries):	75kg (165lbs)	Folded width:	40cm (15.7")
Weight of heaviest part:	37.4kg (82.4lbs) (frame)	Folded length:	83cm (32.7")
Turning circle:	85cm (33.5")	Folded height:	105cm (41.3")

Find out more today!

Visit www.quickiepower.com or www.SunriseMedical.com for more information, to find your local dealer or to request a demonstration.

For further information on the full specification, options and accessories, please refer to the order form. All information is subject to change without notification. Please consult Sunrise Medical with any queries you may have.

If you are visually impaired, this document can be viewed in PDF format at www.SunriseMedical.com or alternatively is available on request in large text.



Get SOCIAL with QUICKIE

Keep up-to-date with the latest news on the Quickie Rumba and other Quickie products through our Facebook page:

www.facebook.com/QuickieWheelchairs



Sunrise Medical Limited
Thorns Road
Brierley Hill
West Midlands
DY5 2LD
Tel: +44 (0) 845 605 66 88
Fax: +44 (0) 845 605 66 89
www.SunriseMedical.com